



Laser Diagnostic Instruments



SUITABLE FOR ATMOSPHERES CONTAINING:

acetaldehyde, ethane, ethyl chloride, ammonia, benzines, gasoline, n-butyl alcohol, diesel, jet engine fuels, acetic acid anhydride, n-hexane, methane, methanol, naphthalene, phenol, propane, toluene



ROWATEX EXD OIL DETECTOR FOR HAZARDOUS AREAS

The ROW ATEX EXD oil detector is designed to be installed within hazardous areas where ignitable concentrations of flammable gases, vapors or mists often exist. These industrial areas are classified as Zone 1 based on established international standards ATEX/IECEX.

› **EXPLOSIVE-PROOF (Ex d) ENCLOSURE**

The ROW ATEX EXD oil detector is encased in a flame-proof (explosion-proof) enclosure made from 316 stainless steel, making it ideal for the toughest environments. The whole system is certified ATEX/IECEX by DNV for Zone 1 installations.

› **TOP CERTIFIED Ex d DEVICE**

LDI, including our entire manufacturing process and instrument model itself, are fully certified by DNV for ATEX & IECEX equipment manufacturing.

› **SPECIFICATIONS: BEST IN CLASS**

Non-contact instrument with robust IP68 protection, low-power (< 2 W) UV fluorescence technology, up to 8 m range - these are the best specs on the market.

› **INDUSTRY LEADING SENSITIVITY - 1µm**

Advanced software algorithms are calibrated to detect oil films down to a single micron layer and minimize false alarms.

› **COMPATIBLE WITH EXISTING DEVICES**

The ROW ATEX EXD can be installed within a network of LDI ROWs but also connect seamlessly with 3rd party telemetry options using RS485 (modbus), 4-20 mA PLC/SCADA, or simple I/O alarm relay.



Italy,
Oil Terminal



Norway,
Fuel Depot

Belgium,
Oil Refinery

Optical non-contact and autonomous sensor for real-time detection of oil contamination - Zone 1 installations

TECHNICAL SPECIFICATIONS

MODELS	O-2301E (ATEX EXD) O-4501E (Light Fraction)	
SENSITIVITY	> 1 µm (micron) oil film	
OIL DETECTION*	O-2301E (ATEX EXD) – Medium (diesel, lubricants etc..) & heavy (crude, bunker fuels etc..) oils O-4501E (Light Fraction) – Light (kerosene, jet fuel etc..), including medium, & heavy oils	
RANGE	up to 8 m [26 ft] from surface; Light Fraction only 5 m [16 ft]	
OPERATION TEMPERATURE	-30°C to +60°C [-22°F to 140°F]	
ENCLOSURE	IP68, hermetically sealed, weather proof Stainless steel 316, Explosion-Proof Enclosure, ATEX/IECEx Zone 1 II 2 G Ex d IIC T6 Gb, Class 1, Division 1, Groups CD	
DIMENSIONS (L x W x H)	677.5 x 132 x 132 mm [26.7 x 5.2 x 5.2 in] device dimensions Comes with external metal bracket for mounting	
WEIGHT	12.2 kg [26.9 lbs]	
POWER OPTIONS (input)	O-2301E (ATEX EXD): 12 – 24 VDC (10V - 30V) O-4501E (Light Fraction): 12 VDC <u>only</u> Optional: 110/220 VAC (60/50 Hz) AC/DC adapter, 24 to 12 VDC adapter, solar/battery options	
POWER USAGE	< 2 Watt (DC)	
LIGHT SOURCE	Pulsed UV LED	
LED LIFETIME	5 years typical, thereafter, LED replacement	
OUTPUTS	[Relay contacts, RS-485 (modbus), 4-20 mA] as standard	
TELEMETRY OPTIONS	RS-232 Ethernet/LAN Audio alarm Wireless Radio Link Wi-Fi GSM	Custom Solutions: Optional adapters available, contact Sales Engineer for additional information
USER INTERFACE	ROW Configurator software for setup & adjustment ROW Manager software for network visualization	
CERTIFICATIONS	EN 61000-6-2, 61000-6-3, 61326-1, 61000-4-2, 61000-4-5, 61000-4-6, 61000-4-8, 61010-1 US EPA: EPA/530/UST-90/009 IP68: EN 60529 ROW ATEX EXD: EN/IEC: 60079-0, 60079-1 ATEX (Zone 1) II 2 G [DNV 20 ATEX 61463X] IECEx Ex d IIC T6 Gb [IECEx PRE 20.0044X]	
WARRANTY	2-years factory warranty as standard, supported worldwide	

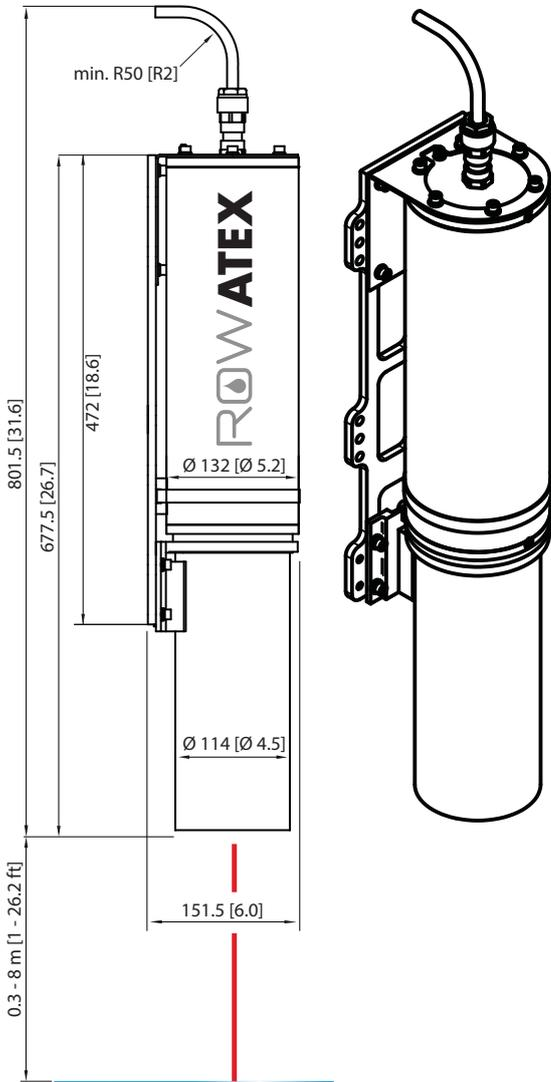
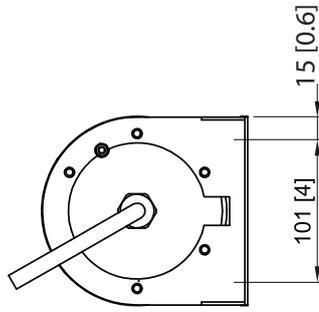

Dimensions unless otherwise stated: mm [inches]

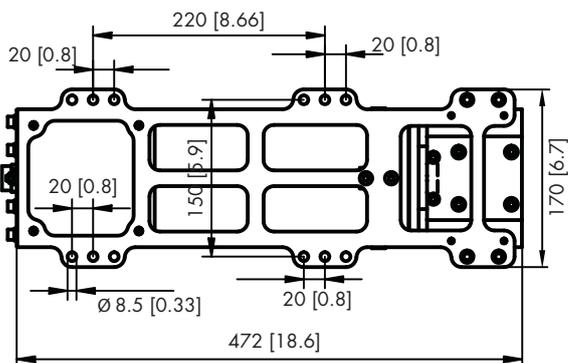

* Different oils from each country have different properties. Check with LDI or send samples for testing.